

Constitution of
the
OFDA International
2015

**OFDA INTERNATIONAL - CONSTITUTION
INDEX
2014**

TITLE	PAGE
Amendments.....	6-7
Approved Targets/Distances	15
Association Championship Rules.....	18
Basic Authority.....	4
Bulletin.....	10
Chairman.....	8
Diagrams Targets & Holsters.....	22-26
Dismissal.....	11
Dissolution.....	21
Dues.....	8
Duties of Officers.....	8-9-10
Elections.....	7
Equipment.....	19-20
Executive Board.....	4
Hall of Fame.....	21-22
Holsters.....	20-21-26
Liability.....	10
Live Ammunition.....	20
Meetings.....	6
Membership.....	5
Name.....	3
Non-Profit Organization.....	4
Officers.....	4
Parliamentary Authority	6
Preamble.....	3
Public Statement of Policy	10
Purposes	3
Quorum.....	4
Range Officer.....	10
Records Keeper	10
Rules of Sanctioned Contest Hosts	11-12
Rules of Sanctioned Matches	12-18
Rules of Sanctioned Matches Part B OWFD.....	17-18
Rules of Sanctioned Competitive Matches.....	12 -16
Safety Director.....	9
Scoring.....	13-14
Secretary and Publicity Director.....	9
Treasurer.....	9
Trustees.....	10
Vice-Chairman.....	8

CONSTITUTION

By-Laws, Standing Rules, Rules of Order, Rules For Sanctioned Competitive Matches of The OFDA INTERNATIONAL Of The State of Ohio, U.S.A.

PREAMBLE

We, the undersigned, do declare ourselves an Association for mutual improvement in the sport of fast draw, and for enlarging our fund of general knowledge; in the pursuit of which we desire to exhibit a due consideration for the feelings and opinions of others; to maintain good sportsmanship and good fellowship in all our activities, and have adopted for government the following Constitution, By-Laws, Rules of Order and Rules for Sanctioned Competitive Matches.

Article I - Name

This organization shall be called the **OFDA INTERNATIONAL**.

Article II - Purposes

Section 1. The OFDA International is dedicated to the cause of helping to make Fast Draw a recognized competitive sport and to promote the safe handling and use of firearms. To be constantly on the alert to protect the American Citizen's Right to possess and use firearms. This Association shall put on shoots for trophies and other prizes and will attend competitive matches sponsored by other clubs and Associations whenever possible.

Section 2. This Association shall oppose the enactment of Laws prejudicial or harmful to said interests, and shall encourage wise and useful Legislation.

Section 3. This Association shall promote skill in, devotion to and understanding of the sport of Fast Draw. Emphasizing conduct becoming to a sportsman, honest rivalry, courteous relations, graceful acceptance of results and the promotion of good fellowship among its Members and Associates.

Section 4. To provide a means of competition with specific rules.

Section 5. To build and maintain among ourselves, in the State in which we meet, in the States and Communities in which we compete and in the area covered by this Constitution and Association a respect for the art of Fast Draw and the people engaged in it.

Section 6. To keep alive the history, legends, traditions and spirit of the "Old West".

Section 7. To provide a means of recognition to members participating and acting in good faith in accordance with the stated purposes of this Association.

Section 8. To provide a means of censure for members acting contrary to the purposes and aims of this Association.

Section 9. The OFDA International shall always strive to be of mutual benefit to all its Members and Associates.

Section 10. That in connection therewith to solicit Membership, establish and collect dues, acquire by purchase or otherwise real estate or personal property, to sell, pledge, mortgage or hypothecate any property which may hereafter be acquired by it, to organize, assist and maintain local clubs and to organize or participate in demonstrations, exhibitions and competitions

Article III - Non-Profit Organization

The OFDA International shall be a non-profit organization and shall have no capital stock. It shall be supported and maintained by the Membership and by benefactions and endowments, as the Executive Board shall determine to be necessary or acceptable for the proper functioning of this Association.

Article IV - Executive Board

Section 1. This Association shall be governed by an Executive Board composed of the Associations' duly elected Officers.

Section 2. The Executive Board shall carry on the administrative, legislative and judicial functions of this Association.

Article V - Basic Authority

The basic authority of the OFDA International is vested in:

1. Laws of the State of Ohio by articles of Incorporation.
2. Constitution and/or by-laws as adopted by this Association from time to time.
3. Parliamentary Authority for ruling, guidance and interpretation.

Article VI - Officers

The officers of this Association shall be:

1. A Chairman
2. Three (3) Vice-Chairmen – one each for the Northern, Southern and Western regions
3. Three (3) Secretaries/Publicity Directors – one each for the Northern, Southern and Western regions
4. A Treasurer
5. Six (6)-Safety Directors – two each for the Northern, Southern and Western regions
6. Three (3) Trustees
7. A Records Keeper
8. Editor (appointed)

The above listed Officers compose the aforementioned Executive Board.

Article VII - Quorum

Section 1. A majority shall constitute a quorum at any regular or special meeting of this Association.

Section 2. A majority of members shall be necessary for the nomination of Association Officers. Nominations shall be held anytime during the weekend of the State Championship match. Voting shall by secret ballot through the mail.

Article VIII - Membership

Section 1. The membership of this Association shall be unlimited except as specified in this Constitution and by-laws.

Section 2. Any person(s) who are interested in the avowed purposes of this Association shall be eligible for Membership, if of good character. All first time requests shall be sent to and reviewed by the Executive Board for final approval/non approval within a thirty day (30) time span. This section does not apply to the Renewal of a current member(s) in good standing. If a person(s) are denied membership, all dues prepaid will be refunded in total by the treasurer. Those denied membership if they choose, can file a written appeal addressed to the executive board. Appeals shall be sent to the OFDA-Chairman to be disseminated to the members of the executive board. The findings of the appeal will be returned to the Chairman for dissemination back to the person(s) who filed.

Membership to the OFDAI will be as follows.

1. **Membership Approved.**
2. **Membership delayed** – pending further review to not last more the 30 days.
3. **Membership denied with the ability to re-file** for the following season. Reasons for the denied ruling will be attached to the membership application and kept with the appropriate OFDAI records.
4. **Membership denied.** Reasons for denied ruling will be attached to the membership application and kept with the appropriate OFDAI records.

Section 3. The OFDA International reserves the right to accept or reject applicants for membership.

Section 4. Any person leaving the Association MUST surrender any and all Association property in his or her possession.

Section 5. The age limit for Membership in the Senior Association shall be 18 years. Adult membership gives the member all rights and privileges including the vote and the opportunity to hold Office.

Section 6. The age limit for membership as the Jr. member is 10 years. Jr. Membership is open to ages 10 to 17 providing the parent or sponsor is a member in good standing. The Jr. Member has all rights and privileges except the right to hold office. The parent or sponsor is directly responsible for all actions of the Jr. Member. Dues for Jr. Members shall be \$7.50 and \$25.00 insurance if he or she is not part of a family membership.

Section 7. Special Honorary Members. Any person may be made an Honorary Member of this Association for some outstanding contribution to the Association or to the support of Fast Draw, at any regular meeting of the Members providing he or she receives two-thirds of said members present and voting.

Section 8. Special Honorary Members are entitled to all the privileges of a regular member, except holding office or voting on any question or motion and shall not be fined for absence, nor called upon for dues.

Section 9. Military Service. Any member entering the Military Service of the United States of America shall be carried as a regular member and shall be free of dues until his or her time of discharge from said service. None of the privileges of a regular member shall be taken away from any member entering the Military Service of this Nation.

Section 10. All members of the OFDA International, Regular, Regular Honorary or Special Honorary shall receive an appropriate membership card. This Association shall assume the expense of this identification card.

Section 11. If a shooter is not a member of the OFDA International or a recognized Association, he/she may shoot as a Maverick, good for 1 (one) time per year. The fee may be applied to his/her dues if he/she joins the Association the same day of the contest. Maverick fee is \$7.50 + \$25.00 (insurance liability fee) = \$32.50. The \$25.00 insurance liability fee must be paid by any non OFDAI member who wishes to compete.

Article IX – Meetings

Section 1. Regular Meetings of the Executive Board shall be held at the discretion of the Executive Board.

Section 2. The Annual Meeting shall be held the weekend of the Association Championship Match.

Section 3. The Chairman of the Executive Board may call special Meetings or Association meetings. Business cannot be conducted unless a majority of the Members are present.

Section 4. Guests may be admitted to any regular or special meeting of the Executive Board by authorization of the Chairman with the approval of the Board.

Section 5. All meetings shall have minutes kept. These minutes shall be published in the official newsletter of the OFDA International.

Article X - Parliamentary Authority

Roberts Rules of Order Revised shall be the parliamentary authority governing this Association in all cases that they are applicable and are not inconsistent with this Constitution and its supplemental sections.

Article XI - Amendments

Section 1. Proposals to add, amend or delete sections to the constitution, by-laws and rules of sanctioned competitive matches must be written, signed and dated.

Section 2. Two (2) copies of proposals being made, one (1) being sent to the Chairman and one (1) being sent to the Secretary.

Section 3. All proposals must be submitted to the Chairman by September 1st, of each year. The Chairman will forward them to the proposal committee for review. The committee must forward the completed reviews to the Chairman by October 1st. The Chairman will then forward them to the Secretary. Proposals may be withdrawn or modified only by the original submitter.

Section 4. All proposals being written will be published in ballot form no later than 11/30. The name of submitter shall be included with each proposal.

Section 5. All ballots will be returned to the Chairman no later than December 31.

Section 6. The Chairman and at least three members will tabulate ballots. The results will be published and mailed to the membership no later than January 31. All newly passed changes or additions will take effect on February 15.

Section 7. In the event of a tie, two-thirds vote of the Executive Board will decide.

Section 8. Ballots will be tabulated, recorded and made public record, thus making previous proposals on

reading void until re-presented.

Section 9. Repealing an Article in the Constitution, by-laws or other sections shall follow the same procedure as amending these sections.

Section 10. Effective 1/1/84 - All proposals for the by-laws changes, additions or deletions must be passed by 2/3 of the voting membership.

Section 11. All voting shall be done by secret ballot.

BY LAWS SECTION Article XII - Elections

Section 1. All Officers shall be elected by secret ballot, nominations having been made from the floor at the annual meeting.

Section 2. It requires a majority to elect to any Office.

Section 3. No Member may hold more than one (1) Office at a time. No member may hold any one office for more than three consecutive terms except for Trustee. A Trustee may also hold any other office.

Section 4. Ballots will be published and mailed to the membership no later than November 30.

Section 4A. Ballots will be returned to the Chairman no later than December 31.

Section 5. Any member in good standing may be nominated for any Office by any other member in good standing.

Section 6. No person shall be nominated for any Office unless he or she is present at the Association meeting to accept or decline the nomination. A nominee for office may be sent a written proxy accepting a particular nomination or may be contacted by phone by the Secretary and accept or decline by phone.

Section 7. The term of Office shall be for one (3) years from date of installation.

Section 8. The Chairman shall accept nominations in the following order: A. Chairman B. Vice-Chairman C. Secretary and Publicity Director D. Treasurer E. Safety Directors and F. Three (3) Trustees.

Section 9. The Chairman and at least three members will tabulate ballots. The results will be published and mailed to the membership no later than January 31.

Section 10. All members of the Executive Board shall have full nominating and voting privileges during the Elections.

Section 11. After all voting is completed and all results are announced by the Chairman, the Chairman shall then instruct that the results of the election shall be made a matter of record and instruct that the ballots be destroyed.

Section 12. All newly elected Officers shall take Office on February 15.

Article XIII - Dues

Section 1. The membership fee shall be \$25.00 per member per year. Additional family members in the same household will pay \$15.00 per year. A \$15.00 initiation fee is required for each member for the first year or after membership has lapsed 60 days. Each member will also pay an assessed insurance fee.

Section 2. Membership shall be for one (1) year from date of payment of dues. Members will be given a sixty- (60) day grace period for renewal. If a member has not renewed within the grace period, said member will be considered a new member and will have to pay the initiation fee.

Section 3. Assessments are to be rarely dealt in, then only after sufficient time has been given to each member to study the situation and express their views. A two-thirds vote of the Executive Board present and voting shall be required to pass on any type of assessment. The rules for amending these by-laws apply for the passage of any assessment.

Section 4. Anyone over 75 years old, that has been an active shooter for 20 years, will be exempt from paying dues.

Section 5. Any paid member of the association will be exempt from paying dues for one year, when they sign up 5 (five) new members within a three-year (3) period.

Article XIV - Duties of Officers

Section 1. Chairman: **The Chairman** shall preside at all meetings of the Assn. and of the Executive Board. The Chairman shall enforce discipline of the Assn. He/she should strive to uphold the dignity of the Association and to maintain its high purpose and ideals. He/she should never lose sight of the fact that he/she is the Chairman of the entire Membership and not a faction, and all his/her acts and decisions should extend justice and courtesy to all. It is his/her duty to represent the Association at all meetings, shoots, and conventions and in all other places where such representation is desirable.

He/she can only be discharged from office through a proper election, or through formal charges substantiated at Executive Board level. The Chairman shall co-ordinate and promote all plans and policies adopted by the Association. He/she shall enforce the Constitution and all attached regulations or cause them to be enforced. The Chairman shall appoint all standing and special committees upon approval of the Executive Board. The Chairman votes like any other member. In case of a tie, he/she shall or may cast the deciding vote if he/she desires, but he/she is not obliged to do so. When there is a difference of only (1) vote, the Chairman may vote with the minority to create a tie. On a vote by roll call the Chairman votes last.

Section 2. Vice-Chairman: The **Vice-Chairman** is to take the chair in the absence of the Chairman or when the Chairman leaves the chair to take part in the proceedings. The Vice-Chairman should keep in touch with all the work of the Association, respond to the request of the Chairman, and act for him/her in his/her absence or at any time when such action is requested.

If, during the absence of the Chairman, an emergency meeting should be requested by the Executive Board, the Vice-Chairman may call it. In the case of the prolonged absence of the Chairman, the Vice-Chairman exercises all the functions of the Chairman except that he/she should not modify any rules and regulations made by the Chairman or launch any new policy. It is a general rule that no temporary Officer can alter a policy or rule of a permanent Officer. The Vice-Chairman becomes Chairman in case of the permanent absence of the Chairman. A person who is not willing to assume the duties of the Chairman when the occasion requires should not accept the Office of Vice-Chairman. The Vice-Chairman shall appoint a co-ordinate for the Annual State Championship Match.

Section 3. Secretary and Publicity Director: The **Secretary** shall keep a record of the proceedings of this association. He/she shall call to order in the absence of the Officers entitled to the chair, and to preside until the election of a Chairman "protempore", which should be immediately. He/she shall call the roll and note absentees, or in voting by yeas and nays, to record the vote of each member. To announce the receipt of all papers addressed to the Association and to certify, when necessary, all papers and proceedings. To write all letters, orders, etc., as the Officers of the Association may direct. To read the minutes of previous meetings, also such papers as are ordered to be read, rising for the purpose. To prepare the credentials. To notify committees of their appointment and to furnish them with necessary papers.

To give his/her signature when necessary. The Secretary's signature should be upon all the writings, sometimes with, and sometimes without that of the Chairman.

The Secretary has the duties of notifying all Members of the Executive Board of all meetings, regular and special. He is to also publish the minutes so that the Members can be kept up to date on decisions made by the Executive Board. He/she is also under obligation of keeping in touch with similar bodies and of reporting to the Association everything that will contribute to its up building. He/she should answer every letter promptly, filing the letter and a copy of his reply. He should send out all notices except those in regard to dues. The secretary is to maintain an up to date address and telephone list of all Members individually, Club and Association wide. He/she should have with them at every meeting a copy of the Constitution, the record of minutes and any other papers that may be necessary. The Secretary must keep a list of all special and standing committees and the name of the Chairman of each.

The Secretary shall be responsible for the dissemination of publicity for the Association. The Secretary shall be responsible for the promotion of the sport for the Association. This shall include producing the brochure for the State Championship and other brochures and advertisements which may be ordered by the Executive Board. Also, to issue all entry blanks for competitive shoots, keeping a complete record of the transactions.

It is the Secretary's duty to supply each member of OFDA with a loose-leaf notebook containing an updated Constitution. Each year the secretary will furnish each contestant with any amendments or changes to the Constitution, which can be added to their notebooks.

The Secretary is the Historian of the Association. His/her record, commonly called the minutes, is the most enduring thing about the organization. The minutes should constitute a record of what is actually done, not the opinion of the Secretary. The Secretary should test his/her minutes by this question: "Would a person, who was not present at the meeting, gain a comprehensive idea of it from these minutes?"

The secretary will keep a copy of the original ballot on proposal, and the results as a permanent record.

Section 4. Treasurer: The **Treasurer** is to receive and hold all monies due the Association, and to pay it out only on it's orders signed by the Chairman and himself. To report in full for all monies whenever the Association may ask. To give a clear and correct statement of it's financial condition. To keep a complete record of all Association property. To notify Members who become delinquent in their dues. To report to the chairman all members who become seriously delinquent in their dues. The Treasurer shall present a report at all meetings of the Association and shall be audited by the Trustees of this Association at the annual meeting. The Treasurer may be bonded. The Treasurer must supply each host club with an updated list of paid members and the names of anyone who has shot as a Maverick for the current season.

The Treasurer will turn in all receipts to the Secretary at the end of the year to be kept with the permanent records.

Section 5. Safety Director: The **Safety Director** is responsible for the safe conduct of all Members in the handling of firearms at all Association functions. He/she will propose to the Executive Board recommendations for disciplinary actions for violations of the Safety Rules and Regulations. Violations of Safety Rules and Regulations will be handled through the proper chain of command. Ordinarily the Chairman is the last resort for a final decision. Some extreme cases may be appealed to the Executive Board at large.

Section 6. Trustees: The **Trustees** shall audit the books of the Treasurer quarterly and report their findings to the Executive Board. An Audit of the books shall also be made at the annual meeting. A person need not be present at the meeting to be nominated for the office and elected a Trustee of this Association. Term of Office for the Trustees shall be a three- (3) year term. Section 3 of Article XII in the by-laws does not pertain to Trustees.

Section 7. Range Officer: At any elimination style contest, the shooting line will be controlled by a **Range Officer**. This person will conduct all activities at the firing line. He/she will direct the shooters as well as the timer operator. The range officer will have the shooters make ready and announce "The Line is Ready" at which time the timer operator will give the command appropriate to the event. The range officer will have sole authority to allow shooters to clear their weapons or to send judges down range. As part of the Range Officer's duties and responsibilities, they should have the final judgement on a shot that the hand judge has a question or discrepancy on. Failure to follow the directions of the range officer will result in a fine of not more than \$5.00 at the range official's discretion.

Section 8. Records Keeper: The **Records Keeper** shall maintain the OFDA Record Book and provide each host club with a copy of their contest events shot and series records. He or she shall be in charge of supplying score sheets to the host clubs.

ARTICLE XV - Public Statements of Policy

No Member shall make any statement of Public Policy in regards to this Association until it has been fully decided by a vote of the Executive Board, and Okayed by the Chairman. No Officer may decide Association Policy unless he has cleared it with the Chairman. No awards shall be given and no manner of awards shall be announced without the prior approval of the Chairman or Executive Board.

ARTICLE XVI - The Bulletin

The news media of this Association shall be known as the Bulletin. It shall be printed at least once a year and distributed to the Members at Association expense. The Secretary of the Association shall be responsible for the publication of the Bulletin. He/she may appoint an Editor and or an Associate Editor with the approval of the Chairman and the Executive Board. It shall be their duty to assemble all news from the various Members and Clubs as well as other Clubs and Associations and print an up-to-date paper. Club Secretaries will be responsible for the dissemination of facts and newsworthy items to the Association Secretary. Any Member in good standing may have their news and views published in this news media. No obscene or dirty jokes are to be printed in the Bulletin. Articles or stories that may be of interest to the members shall be allowed to be printed. The Bulletin must adhere to the high purposes and ideals of this Association.

Upon appointment by the Secretary, the Editor will become part of the Executive Board and will pay dues.

ARTICLE XVII - Liability

The OFDA International does not assume responsibility or liability for the personal negligence of any person or persons in respect to the use of firearms. Careless or unsafe practices in the use of firearms can result in being expelled from this Association.

ARTICLE XVIII - Dismissal

Causes for dismissal of Members and/or Officers shall be as follows:

1. The Board shall have the authority to remove elected officials from office (by majority vote) if said officers are not abiding by all the OFDAI rules & by-laws.
 1. If said officer conduct themselves in a manner unbecoming of OFDAI Officers.
 2. If it is apparent they're not doing their job as set forth in OFDA_ Rules & BY-laws: Non performance of duties or malfeasance in office.
 3. If through their actions show that they are not supporting the OFDAI and office held and/or any act which is deemed detrimental to the good name, membership and order of the OFDA International.
 4. Members and/or Officers can only be dismissed by a two-thirds vote of the Executive Board and only after formal charges have been filed and they have been proven beyond a reasonable doubt.
 5. The board may authorize a change or addition to the Rule Book that is to benefit the safety of the shooters or the OFDAI at any time during the current year, not have to wait till the following year.

ARTICLE XIX - Rules of Sanctioned Contest Hosts

A host club may choose to have a thumbing OFDA International only, open sanction OFDA International or OWFD style. Either sanction must meet the following criteria:

Section 1. Host clubs must submit to Association Secretary date chosen for match, being at least 2 weeks between matches, and phases of competition they have selected for Secretary's okay. The host club must submit their events to the Chairman (60) sixty days in advance of their contest date. The Chairman must notify, in writing, to the host club within (14) fourteen days of the receipt of events with approval of sanction.

Section 2. Host clubs must send individual brochure to all Association members from list provided by the Secretary and to other interested shooters. Must be 30 days in advance of contest.

Section 3. OFDA International will purchase & supply each OFDA International member with a walnut plaque, approx. 8" X 10". It will be presented to the shooter at the first contest he/she attends in which he places in the top 15 places, or in the case of a female shooter, the top 5 positions. The plaque will have an OFDA International medallion and the current year. The host clubs will purchase engraved plates for each sanctioned contest during the current year. The plate will show the date, name of host club or sponsor, title of the shoot, state, men or women, and show place finished for top 15 men and top 5 women. This will include the year-end championship shoot. Host clubs must supply first place awards in the men and women's division at every contest and may supply other awards or trophies for their contests or extra events.

Section 3A. The host of a sanctioned said contest will pay to the OFDAI a sanctioning fee of \$2.00 per shooter in attendance of all sanctioned contests. This fee will be due at the close of said contest from the host.

Section 3B. When a member signs up for a sanctioned OFDA International match, the host club is responsible for requesting that the member show a current, paid-up membership card in order to shoot in the match. If for some reason a member is unable to show a current paid-up membership card and their dues are current, they may request that the host club review the updated list of paid-up members provided by the OFDA International Treasurer.

Section 4. Each club may hold (1) one OFDA International sanctioned match weekend per year as long as there is (7) seven participating clubs or if one club feels they cannot have a sanctioned match, they can forfeit their date to another club. This should insure better attendance

Section 5. The Chairman may allow an OFDA International sanctioned contest to be co-sanctioned by another association. All co-sanctioned contests must be advertised in the OFDA International newsletter in the same way OFDA International originated contests are. All publishing costs must be paid by the contest's originating association.

Section 6. An OFDA International co-sanction may be added to a contest sanctioned by another association if the request is approved by a vote of 2/3's of the Executive Board. A sanction fee of \$10.00 will be paid to the OFDA International for the co-sanction.

Section 6A. In contests that are co-sanctioned by the OFDA International, points will be awarded on the number of OFDA International members shooting in addition to OFDA International travel points.

Section 7. The OFDA International sanction contest season will run between the year-end championship contests, held the first full weekend of November, until the next year-end championship contest.

Section 8. In the case of a two day combined contest, a host may allow shooters to make up the first day's events before the start of the contest on the second day. This will in no way delay the start of the second day's events. This option must be advertised in the official brochure of the contest. If this option is not advertised as stated, NO MAKE UP WILL BE ALLOWED.

Section 9. The thumbing only sanction allows recovery shots and the second shot in doubles to be fanned.

ARTICLE XX – Rules of Sanctioned Matches

Part A: Thumbing OFDA International or Open OFDA International

Section 1. Only single action type revolvers may be used.

Section 2. Minimum barrel length shall be 4 5/8" measured from the front of the cylinder forward.

Section 3. Guns may have only minor alternations to suit individual taste. However, no essential parts may be removed or made inoperative in any way. All parts must be installed and functioning. The New Model Ruger and Ruger Vaquero may be modified to work like the Old Model Ruger. If this is done, they must meet the same criteria as the old models.

Section 4. The notches of the cylinder may be deepened but not intentionally cut through.

Section 5. The trigger guard may be cut down but not cut through.

Section 6. Trigger shoe usage is allowed.

Section 7. Front sights may be removed; rear sights may be removed or altered to suit the individual.

Section 8. Hammer spur may be turned up or out, not to exceed 1/2 inch from the top center of the frame.

Section 9. Hammer shall hold on full cock and half cock when the gun is reasonably jarred. An exception will be the New Model Ruger or other single action revolvers, which feature other safety devises on their original construction.

Section 10 Minimum bore of .30 caliber. Maximum bore is .45 caliber. .22 caliber single action revolvers that have been half bored or full bored and re-barreled to meet the above maybe used as long as they meet all other requirements.

Section 10A. Any revolver not meeting the aforementioned criteria will not be allowed.

Section 11. All guns MUST be loaded in the designated area or areas. All shooters must unload on the line after completion of the phase of shooting. They may load in a barrel provided for that purpose or load on the line. The empty gun shall be checked by the line officer or the hand judge. Unloading consists of removal of all casings and primers and/or the cylinder. Any accidental firing or discharge shall result in a fine. The fine shall not exceed \$5.00.

Section 12. There shall be no looking down the barrel of a gun at any time, except when the cylinder is removed. Any person found violating this section will be fined or disqualified without refund of entry fees, at the direction of the Range Officials.

Section 12A. Shooters must wear eye protection when on the line. This is a safety issue. First offense is a warning. Second offense is a loss of shot. Refusal to wear eye protection will result in immediate disqualification without refund of any moneys.

Section 13. No fancy gun handling or spinning will be permitted except in designated areas. All clubs should have such an area if available. First offense is a warning. Second offense is a fine not to exceed \$5.00 at the discretion of the range officials.

Section 14. The Range Officer or Safety Officer MUST inspect all guns before and after firing. Guns must be unloaded for both inspections. It is not the duty of the Range Officer to index your gun for you. Any contestant not conforming to this rule will be disqualified without refund of any moneys.

Section 15. After the set command is given, the shooter may use Lawman Ready, defined as allowed to touch the gun but the trigger finger must be outside the trigger guard. Attempting to draw/move the gun from the holster prior to the light coming on will be considered an infraction. First offense is a warning, second offense is loss of shot.

Section 16. Conduct a short safety meeting before every contest.

Scoring double target events

The penalty for a miss shall be a maximum of 1.000 per target. The score on the 2nd target shall not exceed 1.000 over the time on the 1st target. The total time shall be as follows:

NUMBER OF HITS

Hit both targets
Hit first, missed second
Missed first, hit second

SCORE

Time on second target
Time on first + 1.000
Time on second + 1.000

The targets will be shot in order from left (first target) to right (second target) for a right-handed contestant and from right (first target) to left (second target) for a left-handed contestant.

If a timer malfunction occurs on hit targets and no other similar scores are available to average, the following shall be allowed:

<u>FIRST TARGET</u>	<u>SECOND TARGET</u>	<u>RULE</u>
Target hit but timer malfunctioned	Target hit but timer malfunctioned	Shoot 'til both targets are hit again, three tries maximum.
Target missed	Target hit but timer malfunctioned	Shoot until both targets are hit. Add 1.000 to second target score.
Target hit but timer malfunctioned	Target missed	Shoot till both targets are hit. Add 1.000 to first target score. Three tries maximum.

If a shooter shoots a recovery shot at the first target and obtains a score & there is a timer malfunction on the second target, the shooter gets the score of the first target plus the average cross-over time of his/her clean sets. In case of the shooter not having a clean set, they get three attempts to establish a crossover time.

In doubles, more than two shots per draw is not allowed. Penalty-no matter if targets are hit or missed, loss of that set and that set only. Shooting more than two shots at doubles constitutes an illegal event.

Section 17. Each miss shall result in the shooter being penalized one second (1.000) for a miss.

Section 17A. In the event a shooter's wax splits, the shooter will be warned the first time and given three minutes to leave the line and address the issue. If it happens again, in the same contest, the shooter will lose the current shot.

Section 18. The actual time recorded will be awarded for each hit, up to one second (1.000). More than one shot per draw, except in doubles, is not allowed. Penalty-no matter if target is hit or missed, loss of that shot and that shot only. Shooting two shots at a single target constitutes an illegal event.

Section 18A. If a record is made at a contest, the shooter will have three tries to "back-up" the record by shooting a shot that is no more than three one-hundredths (.030) of a second slower than the record setting shot. If a shot is "backed-up" and it is a tie for that event, then the contestant shall be listed as a co-holder. If the shot is not "backed-up" successfully, then the shot will count in the contest but will not be entered in the record books maintained by the Records Keeper.

Section 18B. Preserving the Visible Distance Hand Rule Shot and Series Records From 1975-2009 all records were set using the visible distance hand rule. As an honor to the pioneers of fast draw, former members and now deceased shooters, the records at the end of 2009 shall be published as such on the OFDAI website....

Section 19. The only alibi is a malfunction of the timer and/or target. A malfunction is when the target light doesn't shut off when hit. A malfunction is not when the target light does not come on in either standing or in walk and draw.

Section 19A. If a malfunction of the timer and/or target occurs, the contestant will be given a choice of taking an average of his/her clean hits in the phase for that shot, or taking the shot over and accepting the resulting hit or miss. The contestant will be given a maximum of three tries to establish an average if there

are no clean hits during the phase. In the case of step-back or step-up events, the average must be obtained at the distance the malfunction occurred.

Section 19B. The contestant will be given a choice of taking an average of his/her clean hits, or taking the shot over and accepting the results, hit or miss, if there is a clear distraction that caused them to jump the light. (Such as a camera flash or loud noise.)

Section 20. Ties will be broken by three (3) shots fired in each event all shots scoring. In the event prizes are being awarded in each event, the tie will be broken by three (3) shots fired in the event the tie occurs in, all shots scoring.

Section 21. In case of a tie, and a shoot off is necessary, score sheets will be recorded and posted as in a regular event, and each shooter will receive a copy.

Section 22. The contestant's feet (2) plus gun and holster, must be **behind** the line during all standing events. On Walk & Draw, both feet (2) must be **in front** of the line at the time the light comes on. All Walk & Draw events to be shot one contestant at a time. With all contestants for that phase on the line, contestants will alternate until that phase is completed.

Section 23. Decisions of the Judges and Range Officials will be final in all cases.

Section 24. Called off shot...is when a shooter calls off a shot by swinging his arms out to arms length so the judge knows without any doubt that the shooter has called off the shot. Allowed to call off (2) shots per phase. On the shooting line, no more than one minute will be allowed between shots for each shooter. If one minute has expired, the timer operator will give the set command to the shooter. If a shooter asks the timer operator for a practice walk with the light, the shooter may draw but not fire a shot. If a shot is fired, it will be recorded as a miss for their first shot, regardless if the target is hit or not.

Section 25. The shooter is the only one allowed inside the firing area along with the line judge, hand judge and target judge. All others must stay outside the loading area with exception of junior members, who may be accompanied by parent or sponsor. In the case of wax events where greased targets are used, and for blank events where balloon targets are used, one person may judge both hand and target for each shooter.

Section 26. If a mistake is made on a contestant's score sheet and it is not discovered until after the match is over or at a later date, and can be proven by witnesses or a video, a protest can be made at any time within two weeks after the contest is over. If trophies or placement in that contest are involved the adjustments will be made accordingly.

Section 27. Any approved target can be shot with any approved distance. We would have a list of targets and a list of distances. Pick a target then pick a distance.

Approved Targets

18" Wax Silhouette Target
14 1/2" Wax Silhouette World Target
20" Wax Blocker Target
14" Wax Square Target
18" Balloon Disk Target
18" Wax Disk Target
24" Wax Disk Target
9" Wax Disk Target
4" Blank Balloon
9" Blank Balloon

Approved Distances

5' Standing Reaction
6' Standing Reaction
8' Standing Reaction
10' Standing Reaction
12' Standing Reaction
15' Standing Reaction
20' Standing Reaction
21' Standing Reaction
15',12,10,8,5' Step Up Reaction
15',10,5,10,15' Step Up Back Reaction
10',12,15,12,10' Step Back Up Reaction
5',8,10,8,5' Step Back Up Reaction
8',10,12,10,8' Step Back Up Reaction
5',10,15,10,5' Step Back Up Reaction
5',8,10,12,15' Step Back Reaction
5',10,15,20,25' Step Back Reaction
15'-8' Walk & Draw Reaction
21'-15' Walk & Draw Reaction
21' Walk & Draw- Random Time

Section 27A. Wax Doubles or Balloon Doubles may be shot on any approved target at any approved distance.

Section 27B. All practice will cease at least 15 minutes before contest as stated on brochure or contest announcement. This will permit contests to start on time. The second day of a two-day shoot will start no later than 9:30 am.

Section 28. To promote the development and try out of new ideas, the Officers can sanction a contest that does not meet the current phase or scoring requirements. The proposal must be submitted to the Chairman at least 3 months in advance and, upon approval, there must be at least one month's notice to the Association members. This proposal can be sanctioned once and to be used again it must be added to the Constitution.

Section 29. Shooter(s) will indicate their readiness to the timer operator by saying, "SET".

Section 30 If a video camera is present at a contest; its tapes may be used to judge a contestant's shot if a question arises. For example: if a shooter jumped the light, if there was a fast light, etc.

Section 31. Contest to be run as one competitor shooting at a time, either alternating with another competitor, or all 5 shots at a time. Numbers are to be drawn for all shooters for placement except for Men's Top Gun, who will shoot No. 4 and Women's Top Gun who will shoot No. 3 all year.

Section 32. At host club's discretion, they may shoot elimination style (index scoring), but it must be announced in their brochure. No call-offs will be permitted. In walking or double target events, where only one shooter is shooting at a time, the shooter must still take the command as usual.

Section 32A. At any elimination style contest, the shooting line will be controlled by a Range Officer. This person will conduct all activities at the firing line. He/she will direct the shooters as well as the timer operator. The range officer will have the shooters make ready and announce "The Line is Ready" at which time the timer operator will give the command appropriate to the event. The range officer will have sole authority to allow shooters to clear their weapons or to send judges down range. As part of the Range Officer's duties and responsibilities, they should have the final judgment on a shot that the hand judge has a question or discrepancy on. Failure to follow the directions of the range officer will result in a fine of not more than \$5.00 at the range official's discretion.

Section 33. No cell phones on the line and all cell phones are to turn off or the ringer turned down to the lowest possible setting.

Section 34.

A host may hold a classified elimination contest under the following criteria.

- A. 10' Standing Wax only.
- B. OFDA International Silhouette Target only. (18' wide)
- C. One shot per draw. NO CALL OFFS.
- D. Best three out of five wins round.
- E. Three X's to be eliminated.
- F. Shooter may enter any class they choose. (ONLY ONE)
- G. Any shot fired too fast for class will be declared a miss.
- H. All classes will be shot with loser brackets.
- I. Classes will be as follows:
 1. Gunfighter up to .349
 2. Marshall .350 to .449
 3. Sheriff .450 to .549
 4. Deputy .550 to 1.000
- J. Host will provide at least three awards for each class. All awards being equal

- K. Entry fee for each class shall be the same.
- L. Top Gun points will be awarded in each class, based on the number of entrants in the class. You will receive one point for each shooter you beat in your class and the traveling points.
- M. All current gun and holster rules will apply.
- N. Range Officer REQUIRED
- O. Hand and Target Judge REQUIRED. (one person per shooter)
- P. This may be shot as Open or Thumbing Only at the discretion of the Host.
- Q. Elimination contests may not be more than 10% of the total contests in any division.
- R. It is strongly recommended that an elimination event be shot as a single day's contest.

Section 35. Once a contest has begun, *no one* will be allowed to stop the match to test fire their gun, or test fire their primers. There is enough time before the match begins to do this. Reason being: If you are on the line and ready, it can be very disturbing to have the contest stopped for a purpose such as this one.

Section 36. Alcohol consumption or being under the influence in a contest area is strictly prohibited by Participating members and contestants.

Section 37. If hosts choose to give door prizes, they should be allowed to do so during a contest.

ARTICLE XX - Rules of Sanctioned Matches

Part B: OWFD

A host club may choose to have an Old West Fast Draw (OWFD) sanctioned contest. All OFDA rules with the exception of the ones affected by the exclusive OWFD regulations below will apply to all OWFD sanctioned contests.

Section 1. Revolvers: The revolvers to be used for OWFD competition shall be stock from the factory, single action only, with non-adjustable rear sights. The revolver shall have a minimum barrel length of 4 5/8". The only exterior modifications that will be allowed shall be the removal of the front sight and the removal of the knurling or checkering from the hammer spur. The hammer spur may not be turned up or out and must remain stock. Grips may be changed as long as the replacement grips remain stock in size and shape, no oversize, finger groove or bell grips shall be allowed. An internal action job is allowed but all internal parts must remain intact and no short stroke actions will be permitted.

Section 2. Holsters: Any traditional or Hollywood style holster made of leather may be used. The holster shall fit the revolver and the outside of the boot must cover the notches on the cylinder. The front of the boot opening may not be more than 1 ¼ " below where the hammer meets the frame. There must be no boot liners or metal or plastic sewn or glued into or onto the holster or belt. The holster may not exceed a 20 degree angle with the shooter standing in an upright position. Only leather lace holster tie down strings will be allowed, no belt style tie downs with buckles. Deflector plates are optional and spacers to move the holster away from the body will be allowed.

Section 3. Ammunition:

3A – Wax Loads: Wax loads to be used for OWFD competition shall consist of an OFDA approved wax bullet powered by either a large or small pistol primer or a 209 shot shell primer only. No .22 caliber blanks and no powder of any kind will be allowed to propel the wax bullet.

3B – Blank Loads: Blank loads to be used for OWFD competition shall consist of a .45 Colt caliber case loaded only with commercially manufactured rifle, pistol, shot shell or black powders.

Section 4. Shooting Style: The shooting style of OWFD competition may be thumbing or fanning. If fanning style is chosen, the fanning hand may not touch the revolver until after it has been drawn (i.e. no slap-cocking). *The butt of the revolver may not be behind the opening of the holster at the time that the revolver is discharged.*

Section 5. Contest Style: The contest style for OWFD competition shall be chosen by the host club and the contest may be either elimination or index style. If elimination style is chosen it shall be clearly advertised in advance of contest. In OWFD competition only, elimination style can be shot at any approved OFDA target and distance.

Section 6. Clothing: Clothing for OWFD competition shall be western, with period late 1800's style clothing preferred. Western boots or moccasins will be mandatory.

ARTICLE XXI - Association Championship Rules

The Association shall be divided into three (3) regions: Northern, Southern and Western. The Northern regions' boundaries are north of the Kentucky/Tennessee line and east of the Mississippi River. The Southern regions' boundaries are south of the Kentucky/Tennessee border and east of the Mississippi River. The Western regions' boundaries are all states west of the Mississippi River. The Association Champions for each region shall be determined on the following basis:

Section 1. You get 5 points for every shoot that you attend.

Section 2. You get 1 point for every shooter you beat.

Section 3. At the Association Championship Match, all points are double if there is more than 1 match held within the year.

Section 4. All points will be totaled after the Association Championship Match. Highest total will be declared the Top Gun Man and Top Gun Woman in each division.

Section 5. The awards for the Top Guns of each regional division, as determined by the Executive Board, shall be awarded at the end of each regional division's year end contest. Awards 1st through 5th in Men's and 1st through 3rd in Women's will be given.

Section 6. There will be a separate division for men and women.

Section 7. In the event of a tie for Association Champion, three (3) shots shall be fired in each event of the phases used the day of the Championship match, all shots scoring.

Section 8. The Executive Board shall set a budget to cover all the Top Gun expenses each year. This amount shall be approximately 30% of the projected treasury. Each regional division will receive a budget for Top Gun awards based on the number of contests held therein.

Section 9. All shooters in the OFDA International Championship Match must be a member of the OFDA.

Section 10. The Championship may consist of any OFDA International approved target or OFDA International approved phase.

Section 11. There must be a minimum of three (3) contests in any type of sanction to qualify for Top Gun Awards in any regional division.

ARTICLE XXII - Equipment

Section 1. Targets (all black) except for a 1" white border. At the discretion of the host club, the face of the target may be covered with white Lithium grease, in which case the target must be totally black with no 1" white border. This will include ALL metal targets. Section 4 & 5 still apply except for the edge of the target will not be taped.

Section 1A: Drawings with all dimensions for legal targets are included on last page of constitution.

- Section 2.**
- A. Wax targets must be standard 18" X 42" with a white light only which must be located in the upper portion of the target. (Current Ohio target)
 - B. 14" square target with the light in the center of the target. (50" from top to floor.)
 - C. 14 1/2" X 38 1/2" with a white light located in the upper portion of the target (current World target.)
 - D. 18" balloon disc target for wax.
 - E. The opening for the signal light may be round or square. The opening will be a minimum of 3" or a maximum of 4".
 - F. A 20" by 40" rectangle target with a white light located in the center of the target. (64" from top to floor.) Current WFDA Blocker target.
 - G. 24" diameter round, flat, disk target. Light to be located in the center of the disk. The Target height shall be set at 60" from the floor to the top of the target.
 - H. 18" disk 52" from the floor to top of target
 - I. 9" disk with the light in the center of the target. Target height may be set no lower than the shooter's gun belt buckle.

Section 3. When dual targets are used, they must be at least six feet apart. Or allow balloon (blank) targets to be shot face to face (showdown) style. Providing there is a barrier of clear material and strong enough to stop a wax bullet shot at 5' or less, without damage. Timer operator will give command, "Shooter set", and then the timer shall start. There will be no call offs. Malfunctions will make both shooters re-shoot.

Section 4. Paper back drop will be an option. If using paper after each shooter has shot, any holes in the backdrop must be taped. If there is a hole in the paper backdrop and the target reads a hit, unless the tape on the edge of the target is marked because of splitting the wax on edge, it is a miss. When using lithium grease, the front edge of the target must show a half moon to be called a hit.

Section 5. Backdrops shall be at least sixteen (16) feet wide for dual targets, eight (8) feet wide for single targets.

Section 5B Approved Ballistic woven material Model pr-20-b from West Coast Netting can be used as an accepted alternate back stop for sanctioned competitions (8 x 16, quantity of 3 required for 4 targets.)

Section 6. The placement of equipment shall be left to the discretion of the Host club. However, the Host club must comply with the first five sections of this article.

Section 7. Western wear will be mandatory. Western wear means, western pants, western shirt and boots, (moccasins allowed for men and women). Hat is optional.

Section 8. When the set command is given, the random signal to draw shall not come on before two (2) seconds or later than five (5) seconds.

Section 9. Balloon targets will be stationary 42" from the floor to the center of the balloon.

Section 10. When shooting blank 4" balloon targets, they can be adjustable no lower than the shooters holster buckle in a standing straight up position.

Section 11. Only 4", 5" or 6" balloons may be used in 4" balloon targets.

ARTICLE XXIII - Live Ammunition

Section 1. No live ammunition shall be carried into the building or area where a competitive match is being held.

Section 2. The possession of or the use of live ammunition in Fast Draw activities shall constitute a violation of the rules set forth here, and shall be cause of immediate disqualification with forfeiture of any and all fees. It will also cause immediate expulsion from this Association and forfeiture of all rights and privileges thereto.

Section 3. All Fast Draw Competition shall be with wax bullets or blanks.

Section 3A. Only commercially manufactured wax bullets, such as Red Jets, Excalibur, Searls, or Super Speed may be used in competition. Homemade wax approved by the Safety Officers may also be used in competition. The bullets may not be altered in any way that would cause them to split.

Section 3B. Blank loads. Only commercially manufactured rifle, pistol, shotgun or black powders may be used in competition. No shell casing of larger volume than .45 Colt caliber may be used for blank loads.

Section 4. No powder will be used at all to propel wax. Large and small pistol or rifle and shot shell primers shall be the only loads to use with wax loads. Section 4 pertains to all caliber's, .22 acorn and .22 black powder blanks may be used. For wax events, factory primers may not be altered or hot loaded for competition. No stud driver blanks or high power blanks may be used. No .22 blank longer than a .22 short case may be used.

Section 5. At No Time shall any member of the Ohio Fast Draw Association use live rounds to practice the art of Fast Draw. This means in your back yard or anywhere. You may use live rounds for target shooting only.

Section 6. Placement of targets must be parallel with backdrop and not on an angle.

ARTICLE XXIV - HOLSTERS

Section 1. Holsters must be open tops. No swivel, clam shell or spring type holsters will be allowed.

Section 2. The holster's boot shall cover the entire barrel where it enters the frame and 50% of the cylinder and must be leather covered. The holster must be checked with the shooter standing upright.

Section 2a. When using a 22/38 in a traditional holster made for a large frame revolver, a boot liner will be required to hold the gun in the position the holster was designed for.

Section 2b. The revolver must remain in a legal position in the holster when the shooter is in the shooting stance.

Section 3. Maximum tilt shall not exceed forth-five (45) degrees when the shooter is in a shooting stance.

Section 4. Stock holsters manufactured by Ojala, Alfonso, Ernie Hill, Bob Mernickle, Jerry Simpson, etc. are to be considered as standard for the sport of Fast Draw. All holsters, whether commercially or custom made must conform to allowable standards as noted.

Section 5. All holsters must meet the following criteria:

1. The top opening of the boot, excluding liner, shall be a maximum of 2 ¼ " in width and 3 ½ " in length, inside measurement.
2. The bottom of the boot shall be open and shall be a maximum of 1 ½ " in width and 2 ¼ " in length, inside measurement.
3. The holster may not offset more than 2 ½ " from the top inside of the boot to the contestant's body. The holster offset may not exceed 5 ¼ " from the top outside of the boot to the contestant's body.
4. Holsters may be equipped with a deflector shield. The shield may not point at the target or at another contestant while in a shooting stance.

Article XXV – Dissolution

Section 1. Any active member may request dissolution of this organization. The following procedure will be followed in order for dissolution to occur:

Section 2. A request for dissolution must be presented to the board in writing and in person. The board will then debate the pros and cons of such dissolution. A decision (by the board) in favor of dissolution must be unanimous.

Section 3. The general membership will then be polled, each active member having one (1) vote to dissolve or not. A ¾ majority will be necessary for dissolution.

Section 4. If the vote is in favor of dissolution, all of the association's assets will be sold for cash and all bills paid. The remaining cash will then be donated to a charity agreed upon by the board. This will be the last official act of the association.

Article XXVI – Hall of Fame

Section 1. The Executive Board shall create a Hall of Fame which will become a part of the permanent records of the OFDAI

Section 2. The Executive Board shall appoint a Selection Committee of at least three (3) persons. This committee will be responsible for researching the nominees and making the information available to the Executive Board. Any nominee must receive a 2/3 majority vote from the Executive Board to be inducted into the Hall of Fame.

Section 3. Nominations may be submitted to the Chairman at any time. Submissions must be in writing with reasons for the nomination.

Section 4. Criteria for Inductee:

The Person shall have shown an effort to serve and promote the OFDAI above and beyond the norm. Service may include but not limited to: promoting membership, promoting contests, supplying equipment to help new members get started, promoting OFDAI through demonstrations, etc.

Professional organizations may also be considered if they meet the above criteria.

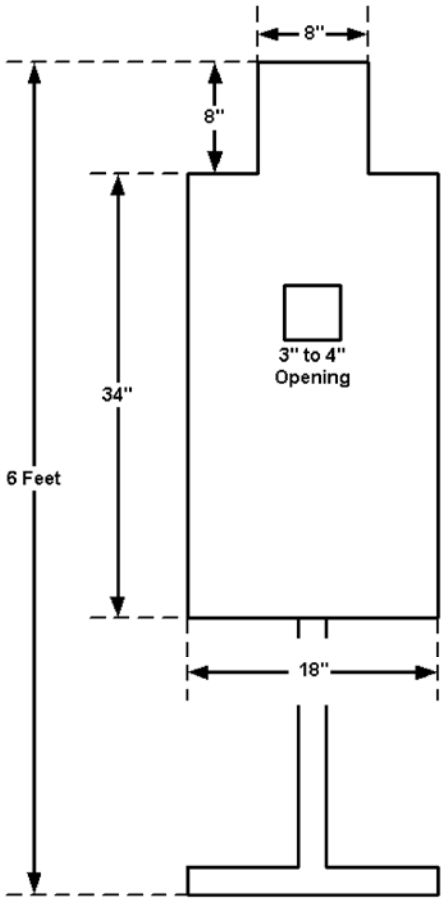

18 "Wax Silhouette Target

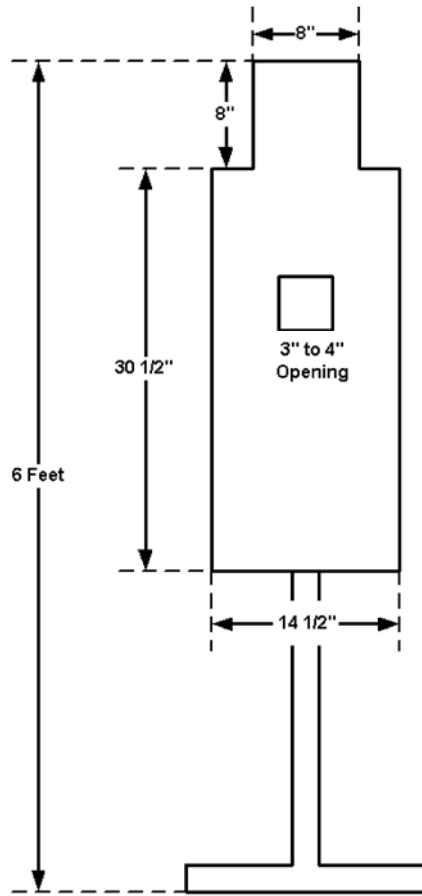

14½" Wax Silhouette World Target

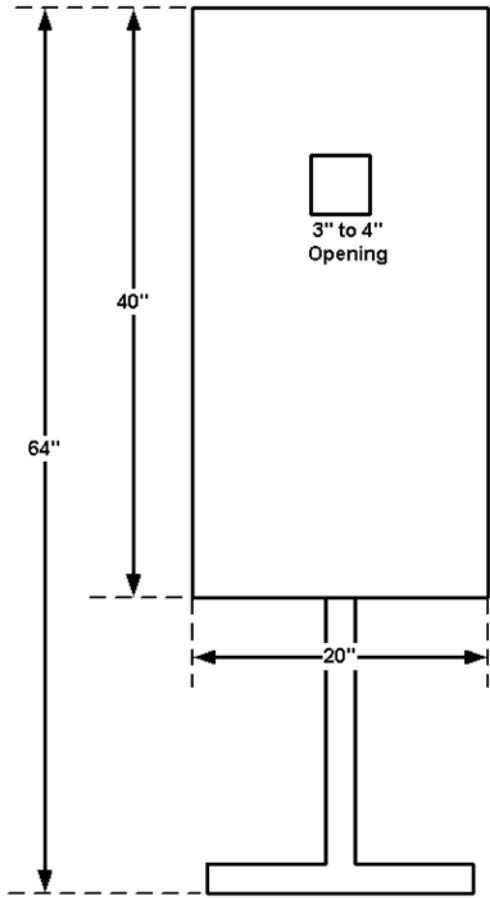

20" Wax Blocker Target

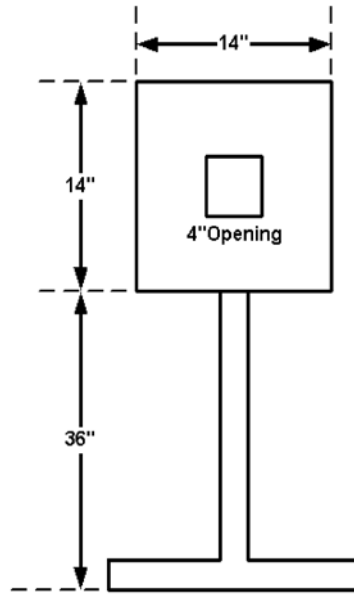

14" Wax Square Target

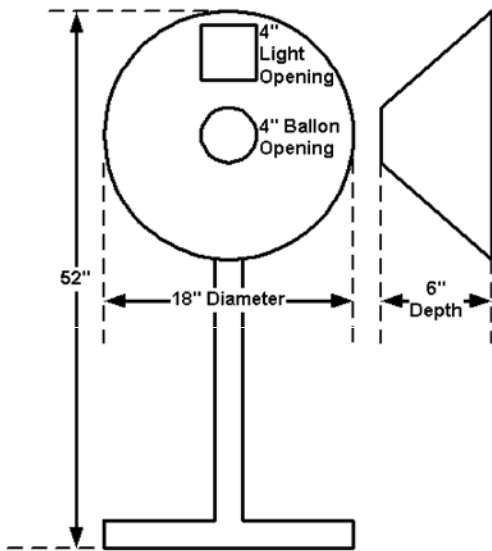

18" Balloon Disk Target

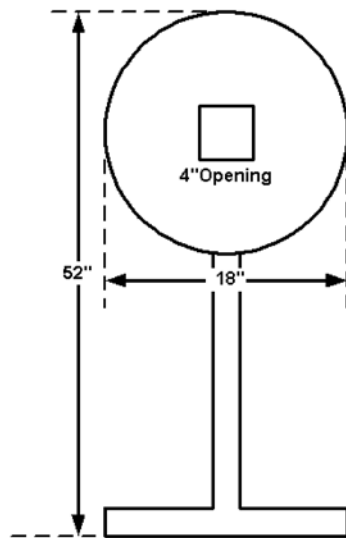

18" Wax Disk Target

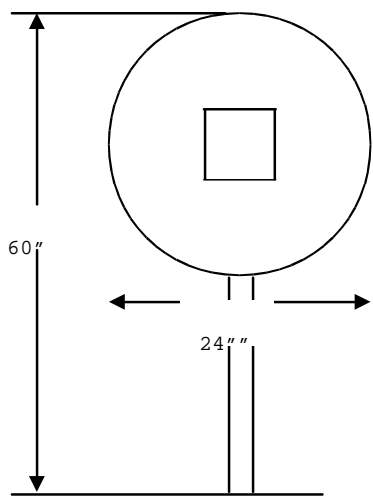

24" Wax Disk Target

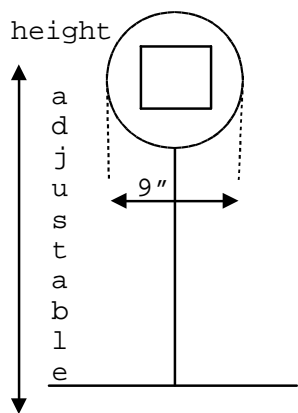

9" Wax Disk Target

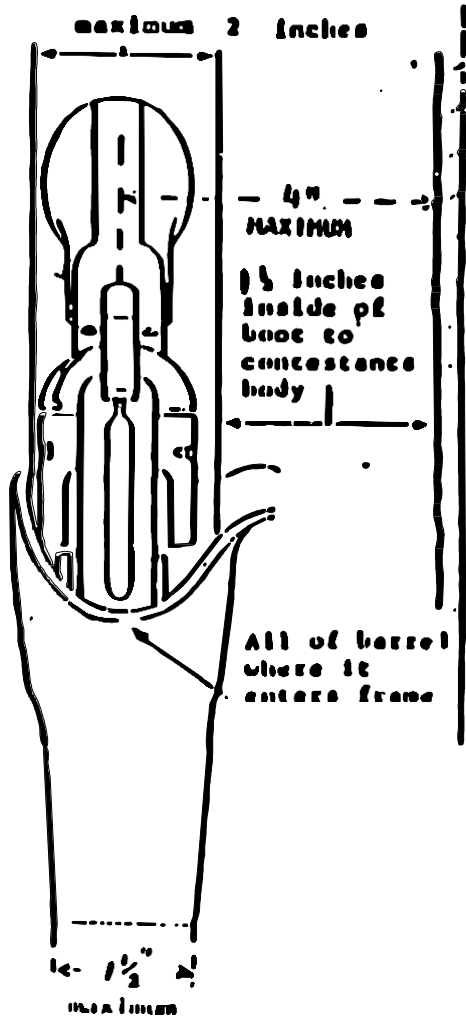

Holster Front

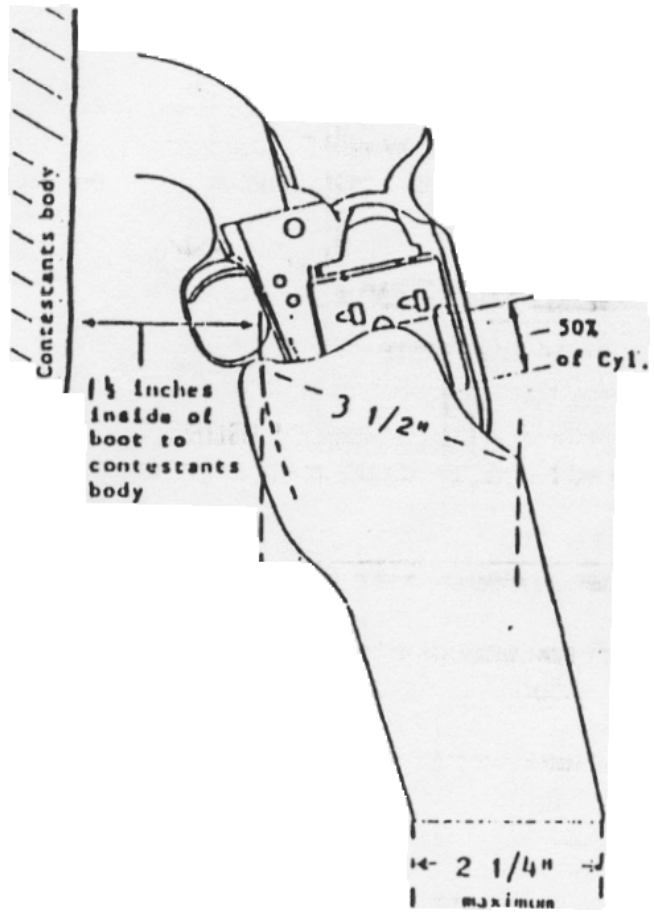

Holster Side